

Frame Size 42mm/60mm/85mm Hollow Shaft Type Motor

■ Features

- Removable coupling connecting Ball-screw, TM-screw directly
- Remove resonance (vibration, noise) without coupling
- Compact design and light weight with high accuracy, speed and torque
- Suitable for small-sized equipment applications
- Cost-effective



Frame size
42mm

60mm

85mm

⚠ Please read "Safety Considerations" in the instruction manual before using.



■ Dimensions

※ Depending on processing of shaft to be assembled, hollow shaft type can be used both single and dual shaft.

◎ Frame size 42mm

(unit: mm)

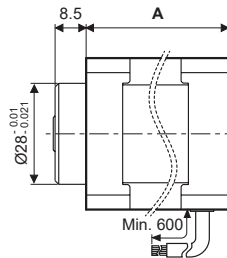
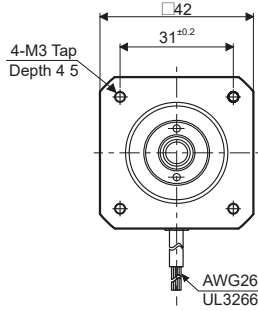

● Hole dimensions

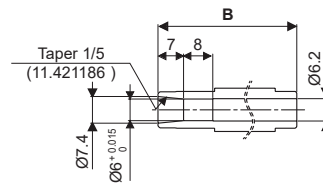

Model	A	B
AH1K-S543-□	33	38
AH2K-S544-□	39	44
AH3K-S545-□	47	52

◎ Frame size 60mm

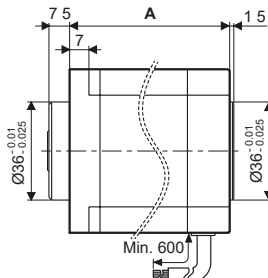
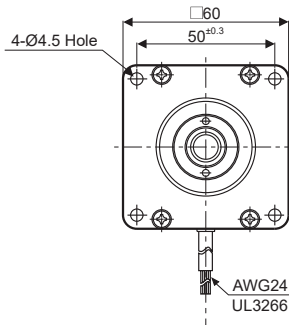

● Hole dimensions

(unit: mm)

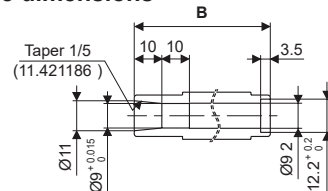

Model	A	B
AH4K-□564(W)-□	48.5	49.3
AH8K-□566(W)-□	59.5	60.3
AH16K-□569(W)-□	89	89.8

◎ Frame size 85mm

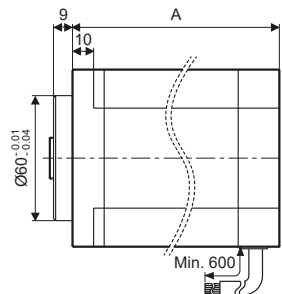
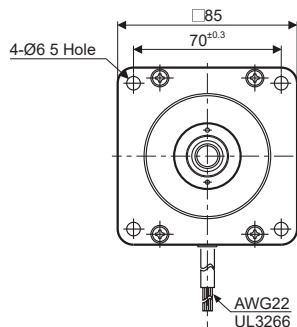

● Hole dimensions

(unit: mm)

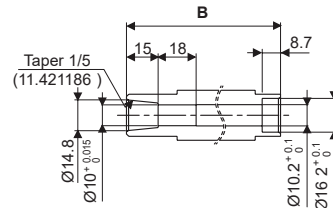

Model	A	B
AH21K-□596(W)-□	68	73
AH41K-□599(W)-□	98	102.5
AH63K-□5913(W)-□	128	133

SENSORS

CONTROLLERS

MOTION DEVICES

SOFTWARE

(Y)
Closed Loop
Stepper System

(Z)
Stepper Motors

(AA)
Drivers

(AB)
Motion
Controllers

AHK Series

Characteristic

● AH1K-S543-□

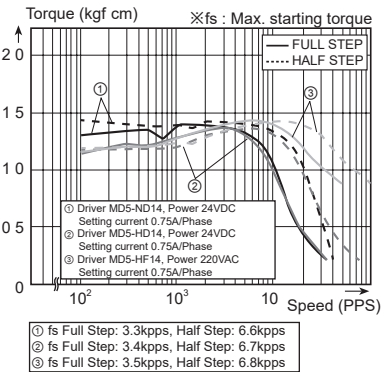

● AH2K-S544-□

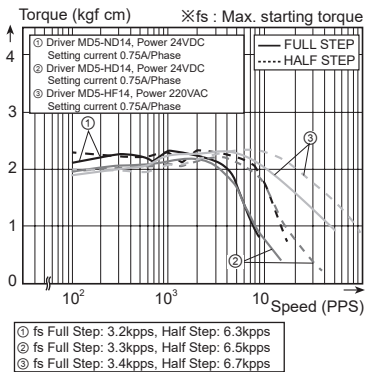

● AH3K-S545-□

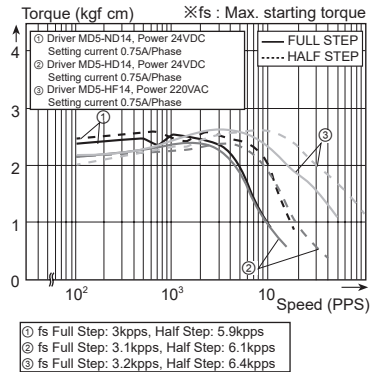

● AH4K-S(M)□564(W)-□

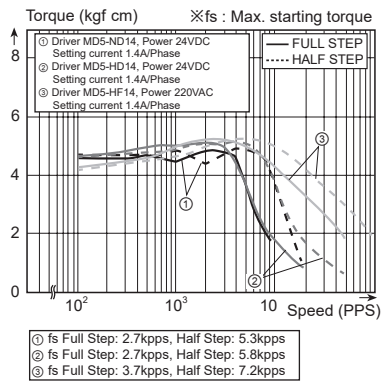

● AH8K-S(M)□566(W)-□

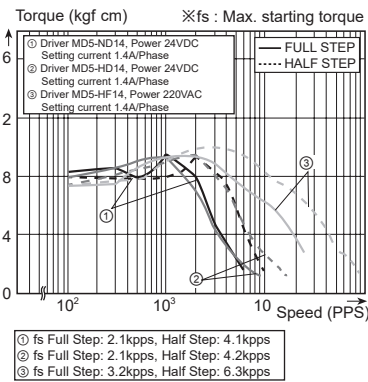

● AH16K-M(G)□569(W)-□

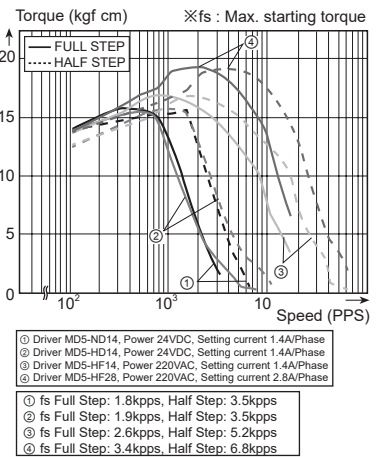

● AH21K-M(G)□596(W)-□

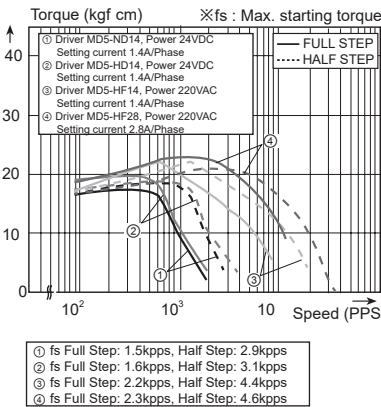

● AH41K-M(G)□599(W)-□

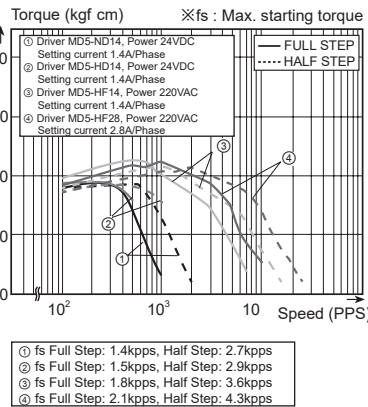

● AH63K-M(G)5913(W)-□

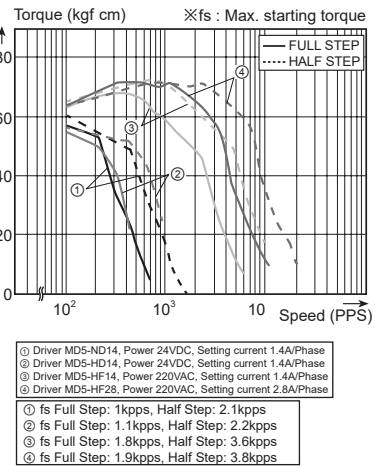

5-Phase Stepper Motor

■ Processing Example for Shaft Assembly

In order to assemble external shafts into Autonics motors, the shafts must be processed as shown in the figures below.

● Single shaft type of frame size 42mm

(unit: mm)

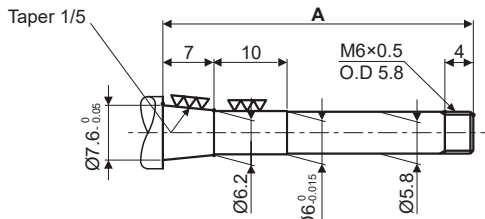

Model	A
AH1K-S543-□	42.5
AH2K-S544-□	48.5
AH3K-S545-□	56.5

※Lock nut is included.

● Dual shaft type of frame size 42mm

(unit: mm)

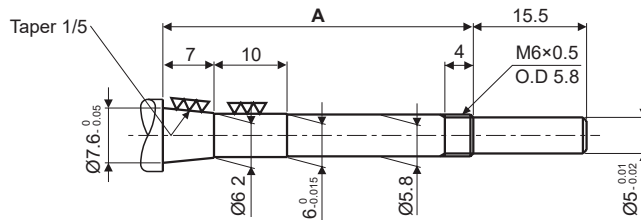

Model	A
AH1K-□543W-□	42.5
AH2K-□544W-□	48.5
AH3K-□545W-□	56.5

※Lock nut is included.

● Single shaft type of frame size 60mm

(unit: mm)

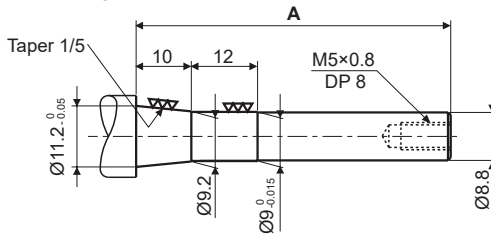

Model	A
AH4K-□564-□	46
AH8K-□566-□	57
AH16K-□569-□	86.5

※Hexagon wrench bolt, flat washer, spring washer and lock washer are included.

● Dual shaft type of frame size 60mm

(unit: mm)

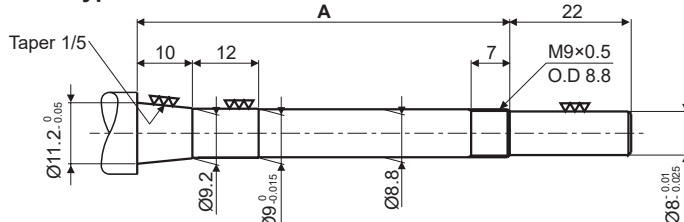

Model	A
AH4K-□564W-□	56.5
AH8K-□566W-□	67.5
AH16K-□569W-□	97

※Lock nut is included.

● Single shaft type of frame size 85mm

(unit: mm)

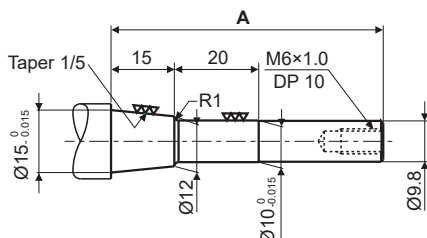

Model	A
AH21K-□596-□	64.5
AH41K-□599-□	94
AH63K-□5913-□	124.5

※Hexagon wrench bolt, flat washer, spring washer and lock washer are included.

● Dual shaft type of frame size 85mm

(unit: mm)

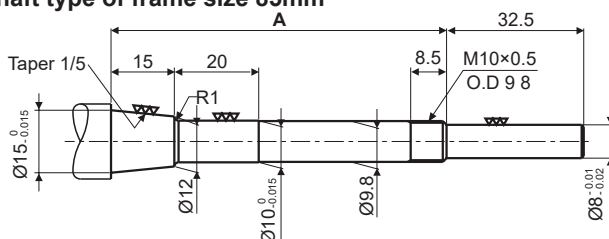

Model	A
AH21K-□596W-□	79.5
AH41K-□599W-□	109.5
AH63K-□5913W-□	139.5

※Lock nut is included.

SENSORS

CONTROLLERS

MOTION DEVICES

SOFTWARE

(Y) Closed Loop Stepper System

(Z) Stepper Motors

(AA) Drivers

(AB) Motion Controllers